

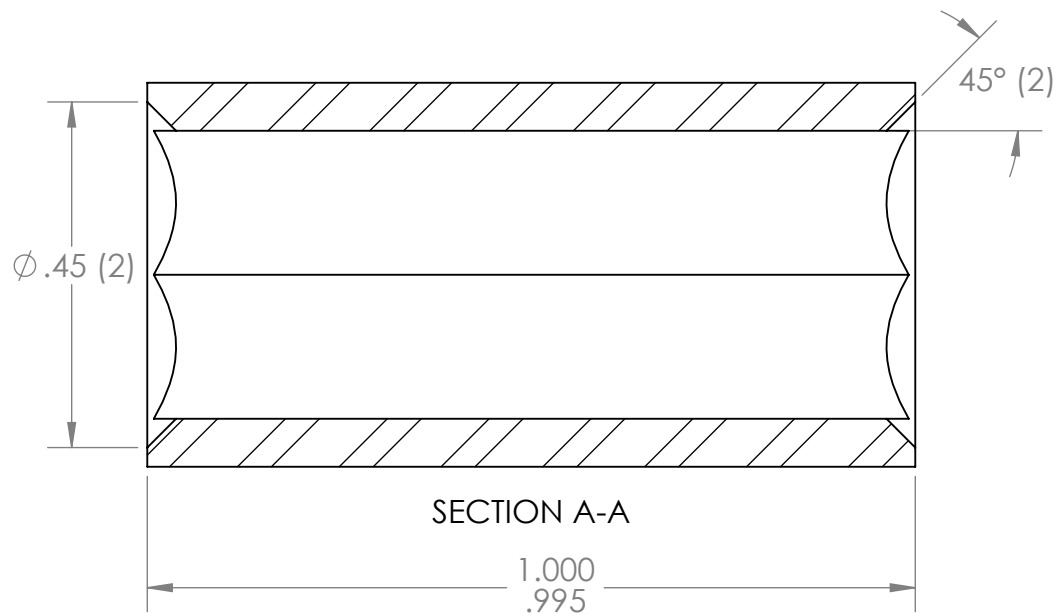

REVISION HISTORY			
REV.	DESCRIPTION	DATE	DRAWN BY
1	ORIGINAL PRINT	10/27/2020	N. MASSOUDA

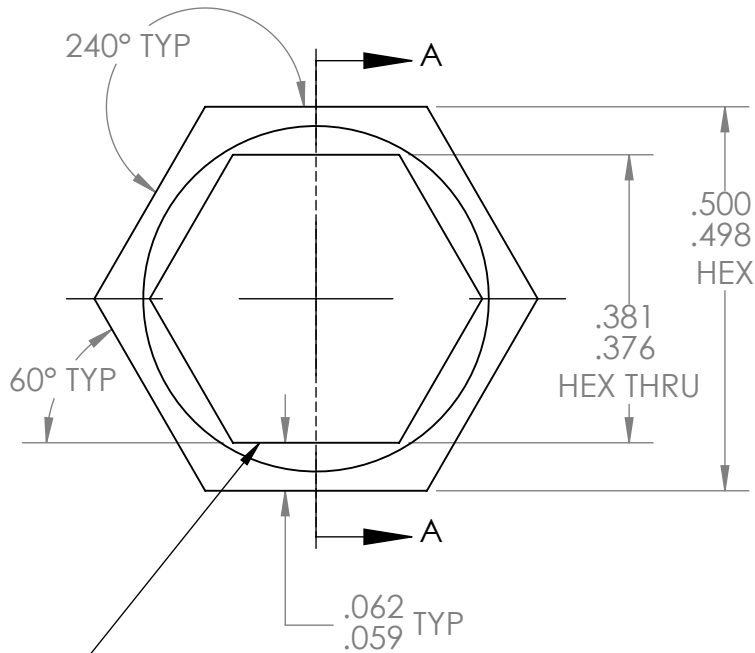

HEX TO HEX CONCENTRICITY  $\pm 0.002$

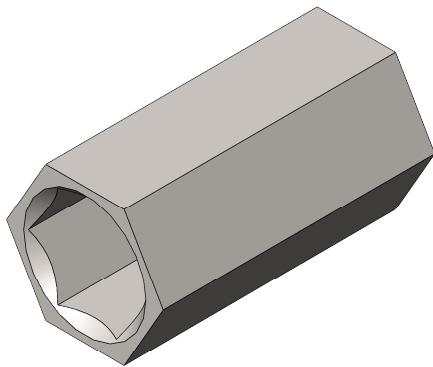

\*\*\* SEE CAD FOR ADDITIONAL TOOLPATH INFO\*\*\*

UNLESS OTHERWISE SPECIFIED:		COMMENTS:			
<b>DIMENSIONS ARE IN INCHES</b>		DUAL DIMENSIONS ARE IN MILLIMETERS.			
TOLERANCES:		BREAK ALL SHARP EDGES		TITLE:	
FRACTIONAL	$\pm 1/16$			500 HEX TO 375 HEX	
ANGULAR: MACH	$\pm 1^\circ$			ADAPTER 1IN LONG	
ANGULAR: BEND	$\pm 5^\circ$			SIZE	DWG. NO.
ONE PLACE DECIMAL	$\pm 0.1$			<b>A</b>	am-3832_long
TWO PLACE DECIMAL	$\pm 0.01$			SCALE: 4:1	WEIGHT:
THREE PLACE DECIMAL	$\pm 0.005$			SHEET 1 OF 1	
FOUR PLACE DECIMAL	$\pm 0.0005$				
MATERIAL	4140 STEEL	NAME	DATE	REV	
FINISH	DEBURRED ZINC PLATED	CHECKED	NL	10/28/20	1
		ENG APPR.			
		MFG APPR.			
	DO NOT SCALE DRAWING	Q.A.			